





N1040 Controller

TEMPERATURE CONTROLLER – INSTRUCTIONS MANUAL – V2.0x C

SAFETY ALERTS

The symbols below are used on the equipment and throughout this document to draw the user's attention to important operational and safety information.

	
CAUTION: Read the manual thoroughly before installing and operating the equipment.	CAUTION OR DANGER: Electrical shock hazard

All safety related instructions that appear in the manual must be observed to ensure personal safety and to prevent damage to either the instrument or the system. If the instrument is used in a manner not specified by the manufacturer, the protection provided by the equipment may be impaired.

INSTALLATION / CONNECTIONS

The controller must be fastened on a panel, following the sequence of steps described below:

- Prepare a panel cut-out according Specifications;
- Remove the mounting clamps from the controller;
- Insert the controller into the panel cut-out;
- Slide the mounting clamp from the rear to a firm grip at the panel.

ELECTRICAL CONNECTIONS

Fig. 01 below shows the electrical terminals of the controller:

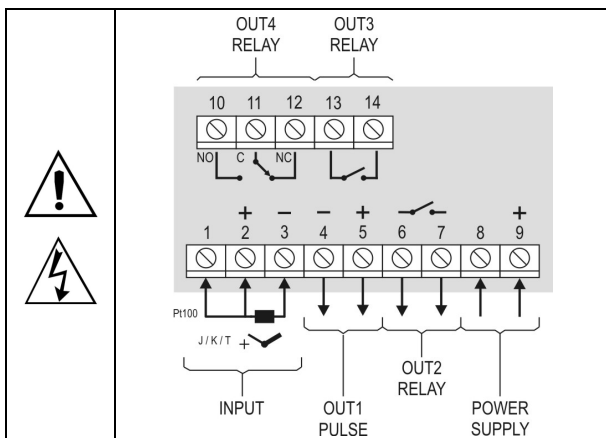

Fig. 01 - Connections of the back panel

RECOMMENDATIONS FOR THE INSTALLATION

- All electrical connections are made to the screw terminals at the rear of the controller.
- To minimize the pick-up of electrical noise, the low voltage DC connections and the sensor input wiring should be routed away from high-current power conductors. If this is impractical, use shielded cables. In general, keep cable lengths to a minimum.
- All electronic instruments must be powered by a clean mains supply, proper for instrumentation.
- It is strongly recommended to apply RC'S FILTERS (noise suppressor) to contactor coils, solenoids, etc. In any application it is essential to consider what can happen when any part of the system fails. The controller features by themselves can not assure total protection.

FEATURES

INPUT TYPE SELECTION

Table 01 shows the sensor types accepted and their respective codes and ranges. Access the parameter **TYPE** in the INPUT cycle to select the appropriate sensor.

TYPE	CODE	RANGE OF MEASUREMENT
Thermocouple J	tc J	Range: -110 to 950 °C (-166 to 1742 °F)
Thermocouple K	tc P	Range: -150 to 1370 °C (-238 to 2498 °F)
Thermocouple T	tc t	Range: -160 to 400 °C (-256 to 752 °F)
Pt100	Pt	Range: -200 to 850 °C (-328 to 1562 °F)

Table 01 – Input types

OUTPUTS

The controller offers two, three or four output channels, depending on the loaded optional features. The output channels are user configurable as **Control Output**, **Alarm 1 Output**, **Alarm 2 Output**, **Alarm 1 OR Alarm 2 Output** and **LBD (Loop Break Detect) Output**.

OUT1 - Logical pulse, 5 Vdc / 25 mA, available at terminals 4 and 5.

OUT2 - Relay SPST-NA. Available at terminals 6 and 7.

OUT3 - Relay SPST-NA. Available at terminals 13 and 14.

OUT4 - Relay SPDT, available at terminals 10, 11 and 12.

CONTROL OUTPUT

The control strategy can be **ON/OFF** (when **Pb = 0.0**) or **PID**. The PID parameters can be automatically determined enabling the auto-tuning function (**Retun**).

ALARM OUTPUT

The controller contains 2 alarms that can be directed (assigned) to any output channel. The alarm functions are described in **Table 02**.

oFF	Output is not used as alarm.	
Lo	Alarm of Absolute Minimum Value. Triggers when the value of measured PV is below the value defined for alarm <i>Setpoint</i> .	
Hi	Alarm of Absolute Maximum Value. Triggers when the value of measured PV is above the value defined for alarm <i>Setpoint</i> .	
dIF	Alarm of Differential Value. In this function the parameters SPA1 and SPA2 represent the deviation of PV in relation to the SP of CONTROL.	
	<div style="display: flex; justify-content: space-around;"> <div style="text-align: center;"> <p>Positive SPA1</p> </div> <div style="text-align: center;"> <p>Negative SPA1</p> </div> </div>	
dIFL	Alarm of Minimum Differential Value. It triggers when the value of PV is below the defined point by (using the Alarm 1 as example).	
	<div style="display: flex; justify-content: space-around;"> <div style="text-align: center;"> <p>Positive SPA1</p> </div> <div style="text-align: center;"> <p>Negative SPA1</p> </div> </div>	
dIFH	Alarm of Valor Maximum Differential Value. Triggers when the value of PV is above the defined point by (using Alarm 1 as example):	
	<div style="display: flex; justify-content: space-around;"> <div style="text-align: center;"> <p>Positive SPA1</p> </div> <div style="text-align: center;"> <p>Negative SPA1</p> </div> </div>	
IErr	Alarms of the Sensor Break (Sensor <i>Break Alarm</i>). It is activated when the Input presents problems such as interrupted sensor, bad connection, etc.	

Table 02 – Alarm functions

Note: Alarm functions on **Table 02** are also valid for Alarm 2 (SPA2).

INITIAL BLOCKING OF ALARM

The **initial blocking** option inhibits the alarm from being recognized if an alarm condition is present when the controller is first energized (or after a transition from run YES → NO). The alarm will be enabled only after the occurrence of a non-alarm condition followed by a new occurrence for the alarm.

The initial blocking is useful, for instance, when one of the alarms is configured as a minimum value alarm, causing the activation of the alarm soon upon the process start-up, an occurrence that may be undesirable.

The initial blocking is disabled for the sensor break alarm function **IErr**.

SAFE OUTPUT VALUE WITH SENSOR FAILURE

This function defines an output value (user defined) to be assigned to the control output in the event of a sensor failure.

When the input sensor is identified as broken, the controller switches the control mode to MANUAL while forcing MV to assume the user configured value in the **IEou** parameter. This function requires that one of the alarms be configured as **IErr** and the **IEou** parameter (control output percentage) programmed with a value other than 0 (zero).

Once this function is triggered, the controller remains in SAFE mode (MANUAL control output) even after the sensor failure appears to be fixed. The operator intervention is required for switching back to AUTO mode.

IEou values are only 0 and 100 % when in ON/OFF control mode. For PID control mode any value in the range from 0 to 100 % is accepted.

LBD FUNCTION – LOOP BREAK DETECTION

The parameter defines a time interval, in minutes, within which the PV is expect to react to a control output signal. If the PV does not react properly within the time interval configured in **Lbdct**, the controller interprets this as a control loop break and signals this occurrence in the display.

A LBD event may be sent to any output channel. Simply configure the LBD function to the desired output channel (OUT1 or OUT2): the selected output will be activated when a LBD condition is detected. When the **Lbdct** parameter is programmed with 0 (zero), the LBD function is disabled.

The LBD is useful in detecting system failures, such us defective sensors or actuators, loads and power supply, among others.

OFFSET

Allows fine adjustments to the PV reading for compensation of sensor error.

USB INTERFACE

The USB interface is used for CONFIGURING or MONITORING the controller. The **NConfig** software must be used for the configuration. It makes it possible to create, view, save and open configurations from the equipment or files in your computer. The tool for saving and opening configurations in files makes it possible to transfer configurations between pieces of equipment and to make backup copies. For specific models, the **NConfig** software also makes it possible to update the firmware (internal software) of the controller through the USB.

For MONITORING purposes you can use any supervisory software (SCADA) or laboratory software that supports the MODBUS RTU communication on a serial communications port. When connected to the USB of a computer, the controller is recognized as a conventional serial port (COM x). Use the **NConfig** software or consult the DEVICE MANAGER in the Windows CONTROL PANEL to identify the COM port that was assigned to the controller. Consult the mapping of the MODBUS memory in the controller’s communications manual and the documentation of your supervisory software to conduct the MONITORING process.

Follow the procedure below to use the USB communication of the equipment:

1. Download the **NConfig** software from our website and install it on your computer. The USB drivers necessary for operating the communication will be installed together with the software.
2. Connect the USB cable between the equipment and the computer. The controller does not have to be connected to a power supply. The USB will provide enough power to operate the communication (other equipment functions cannot operate).
3. Open the **NConfig** software, configure the communication and start recognition of the device.

The USB interface IS NOT SEPARATE from the signal input (PV) or the controller’s digital inputs and outputs. It is intended for temporary use during CONFIGURATION and MONITORING periods. For the safety of people and equipment, it must only be used when the piece of equipment is completely disconnected from the input/output signals. Using the USB in any other type of connection is possible but requires a careful analysis by the person responsible for installing it.

OPERATION

The controller's front panel, with its parts, can be seen in the Fig. 02:



Fig. 02 - Identification of the parts referring to the front panel

Display of PV / Programming (top display, red color): Displays the current value of PV (*Process Variable*). When in configuration mode, it shows the parameters names.

Display of SP / Parameters (bottom display, green color): Displays the value of SP (*Setpoint*). When in configuration mode, it shows the parameters values.

TUNE Indicator: Stays ON while the controller is in tuning process.

OUT Indicator: For relay or pulse control output; it reflects the actual state of the output.

A1 and A2 Indicators: signalize the occurrence of alarm situation.

P Key: used to walk through the menu parameters.

▲ Increment key and ▼ - Decrement key: allow altering the values of the parameters.

◀ Back key: used to retrocede parameters.

OPERATION

When the controller is powered up, it displays its firmware version for 3 seconds, after which the controller starts normal operation. The value of PV and SP is then displayed and the outputs are enabled.

In order for the controller to operate properly in a process, its parameters need to be configured first, such that it can perform accordingly to the system requirements. The user must be aware of the importance of each parameter and for each one determine a valid condition.

The parameters are grouped in levels according to their functionality and operation easiness. The 5 levels of parameters are:

- 1 – Operation / 2 – Tuning / 3 – Alarms / 4 – Input / 5 – Calibration

The "P" key is used for accessing the parameters within a level.

Keeping the "P" key pressed, at every 2 seconds the controller jumps to the next level of parameters, showing the first parameter of each level:

PV >> *ALen* >> *FuRI* >> *TYPE* >> *PASS* >> PV ...

To enter a particular level, simply release the "P" key when the first parameter in that level is displayed. To walk through the parameters in a level, press the "P" key with short strokes. To go back to the previous parameter in a cycle, press ◀:

Each parameter is displayed with its prompt in the upper display and value/condition in the lower display. Depending on the level of parameter protection adopted, the parameter *PASS* precedes the first parameter in the level where the protection becomes active. See section **Configuration Protection**.

DESCRIPTION OF THE PARAMETERS

OPERATION CYCLE

PV + SP	PV Indication screen. On the higher display (red) the value of the measured variable (PV) temperature is shown. On the lower display (green), the control setpoint (SP) is shown.
SPR1 SPR2	Alarm SP: Value that defines the alarm activation point. For the alarms set up with the functions of the type Differential , these parameters define deviations. For the alarm function IErr , this parameter is not used. Parameters shown in this level only when enabled in the parameters SP1E and SP2E .

TUNING CYCLE

ALen	AUTO-TUNE: enables the auto-tuning function for the PID parameters (Pb , Ir , dE). Defines the control strategy to be taken: oFF - Turned off. (no PID tuning) FASt - Automatic tuning. FULL - More accurate automatic tuning. Refer to the section DETERMINATION OF PID PARAMETERS for more details.
Pb	Proportional Band - Value of the term P of the control mode PID, in percentage of the maximum span of the input type. Adjust of between 0 and 500.0 %. When set to zero (0), control action is ON/OFF.
Ir	Integral Rate - Value of the term I of the PID algorithm, in repetitions per minute (Reset). Adjustable between 0 and 24.00. Displayed only if proportional band ≠ 0.
dE	Derivative Time - Value of the term D of the control mode PID, in seconds. Adjustable between 0 and 250.0 seconds. Displayed only if proportional band ≠ 0.
CE	Cycle time: Pulse Width Modulation (PWM) period in seconds. Adjustable between 0.5 and 100.0 seconds. Displayed only if proportional band ≠ 0.
HYSL	Control hysteresis: Is the hysteresis for ON/OFF control (set in temperature units). This parameter is only used when the controller is in ON/OFF mode (Pb=0).
ACE	Action Control: rE Control with Reverse Action . Appropriate for heating . Turns control output on when PV is below SP. dIr Control with Direct Action . Appropriate for cooling . Turns control output on when PV is above SP.
SFSL	SoftStart Function – Time interval, in seconds, while the controller limits the control output (MV) rising rate. (zero value disables the Soft start function).
Out1 Out2 Out3 Out4	Assign functions to the Output channels OUT1, OUT2, OUT3 and OUT4: oFF - Not used. Ctrl - Control output. R1 - Alarm 1 output. R2 - Alarm 2 output. R1R2 - Alarm 1 + Alarm2 (OR logic). Lbd - Loop Break Detect Alarm.

ALARMS CYCLE

F_uA 1 F_uA 2	Functions of Alarms. Defines the functions for the alarms among the options of the Table 02 .
S_PA 1 S_PA 2	Alarm SP: Value that defines the point of activation of the alarm outputs. For the alarms programmed with the functions of the type Differential , these parameters represent the deviations. For the IErr alarm function, this parameter has no meaning.
S_P I_E S_P 2_E	Configures display of SPA1 and SPA2 also in the Operation Cycle. YES - SPA1/SPA2 are displayed in the Operation Cycle no - SPA1/SPA2 are not displayed in the Operation Cycle
b_LA 1 b_LA 2	Blocking Alarms. YES - Enables initial blocking no - Inhibits initial blocking
H_YA 1 H_YA 2	Alarm Hysteresis. Defines the difference between the value of PV at which the alarm is triggered and the value at which it is turned off.
FLSh	Allows visual signalization of an alarm occurrence by flashing the indication of PV in the operation level. YES - Enables alarm signaling flashing PV no - Disables alarm signaling flashing PV

INPUT CYCLE

TYPE	Input Type: Selects the input signal type to be connected to the process variable input. Refer to Table 01 for the available options. (J): tc J -110 to 950 °C / -166 to 1742 °F (K): tc P -150 to 1370 °C / -238 to 2498 °F (T): tc t -160 to 400 °C / -256 to 752 °F (Pt100): Pt -200 to 850 °C / -328 to 1562 °F
FLtr	Digital Input Filter - Used to improve the stability of the measured signal (PV). Adjustable between 0 and 20. In 0 (zero) it means filter turned off and 20 means maximum filter. The higher the filter value, the slower is the response of the measured value.
dPPo	Selects the decimal point position to be viewed in both PV and SP.
un: t	Selects display indication for degrees Celsius or Fahrenheit: C - Indication in Celsius. F - Indication in Fahrenheit.
OFFS	Sensor Offset: Offset value to be added to the PV reading to compensate sensor error. Default value: zero.
SPLL	Defines the SP lower limit of.
SPHL	Defines the upper limit for adjustment of SP.
Lbdt	Time interval for the LBD function. Defines the maximum interval of time for the PV to react to a control command. In minutes.
IEou	Percentage value to be applied to the output on any failure of the sensor that is connected to the controller input.

CALIBRATION CYCLE

All types of input are calibrated in the factory. In case a recalibration is required; it shall be carried out by a specialized professional. In case this cycle is accidentally accessed, do not perform alteration in its parameters.

PASS	Password . This parameter is presented before the protected cycles. See item Protection of Configuration.
CALib	Calibration . Enables the possibility for calibration of the indicator. When the calibration is not enabled, the related parameters are hidden.
inLC	Input Low Calibration . Enter the value corresponding to the low scale signal applied to the analog input.
inHC	Input High Calibration . Enter the value corresponding to the full scale signal applied to the analog input.
rStr	Restore . Restores the factory calibration for all inputs and outputs, disregarding modifications carried out by the user.
CJ	Cold Junction . This screen is for information purpose only.
PASC	Password Change . Allows defining a new access password, always different from zero.
Prot	Protection . Sets up the Level of Protection. See Table 04 .

CONFIGURATION PROTECTION

The controller provides means for protecting the parameters configurations, not allowing modifications to the parameters values, avoiding tampering or improper manipulation. The parameter **Protection (Prot)**, in the Calibration level, determines the protection strategy, limiting the access to particular levels, as shown by the **Table 04**.

PROTECTION LEVEL	PROTECTION LEVELS
1	Only the Calibration level is protected.
2	Calibration and Input levels.
3	Calibration, Input and Alarms levels.
4	Calibration, Input, Alarms and Tuning levels.
5	All levels are protected, but the SP screen in the operation level.
6	All levels are protected, including SP.

Table 04 – Levels of Protection for the Configuration

ACCESS PASSWORD

The protected levels, when accessed, request the user to provide the **Access Password** for granting permission to change the configuration of the parameters on these levels.

The prompt **PASS** precedes the parameters on the protected levels. If no password is entered, the parameters of the protected levels can only be visualized.

The Access Password is defined by the user in the parameter **Password Change (PASC)**, present in the Calibration Level. **The factory default for the password code is 1111.**

PROTECTION ACCESS PASSWORD

The protection system built into the controller blocks for 10 minutes the access to protected parameters after 5 consecutive frustrated attempts of guessing the correct password.

MASTER PASSWORD

The Master Password is intended for allowing the user to define a new password in the event of it being forgotten. The Master Password doesn't grant access to all parameters, only to the **Password Change** parameter (**PASC**). After defining the new password, the protected parameters may be accessed (and modified) using this new password.

The master password is made up by the last three digits of the serial number of the controller **added** to the number 9000. As an example, for the equipment with serial number 07154321, the master password is 9321.

Controller serial number is displayed by pressing **◀** for 3 seconds.

DETERMINATION OF PID PARAMETERS

During the process of determining automatically the PID parameters, the system is controlled in **ON/OFF** in the programmed Setpoint. The auto-tuning process may take several minutes to be completed, depending on the system. The steps for executing the PID auto-tuning are:

- Select the process Setpoint.
- Enable auto-tuning at the parameter "**REUn**", selecting **FRSt** or **FULL**.

The option **FRSt** performs the tuning in the minimum possible time, while the option **FULL** gives priority to accuracy over the speed.

The sign TUNE remains lit during the whole tuning phase. The user must wait for the tuning to be completed before using the controller.

During auto tuning period the controller will impose oscillations to the process. PV will oscillate around the programmed set point and controller output will switch on and off many times.

If the tuning does not result in a satisfactory control, refer to **Table 05** for guidelines on how to correct the behavior of the process.

PARAMETER	VERIFIED PROBLEM	SOLUTION
Band Proportional	Slow answer	Decrease
	Great oscillation	Increase
Rate Integration	Slow answer	Increase
	Great oscillation	Decrease
Derivative Time	Slow answer or instability	Decrease
	Great oscillation	Increase

Table 05 - Guidance for manual adjustment of the PID parameters

For further details on PID tuning, visit our web site: www.novusautomation.com.

MAINTENANCE

PROBLEMS WITH THE CONTROLLER

Connection errors and inadequate programming are the most common errors found during the controller operation. A final revision may avoid loss of time and damages.

The controller displays some messages to help the user identify problems.

MESSAGE	DESCRIPTION OF THE PROBLEM
----	Open input. No sensor or signal.
Err 1 Err 6	Connection and/or configuration problems. Check the wiring and the configuration.

Other error messages may indicate hardware problems requiring maintenance service.

CALIBRATION OF THE INPUT

All inputs are factory calibrated and recalibration should only be done by qualified personnel. If you are not familiar with these procedures do not attempt to calibrate this instrument.

The calibration steps are:

- Configure the input type to be calibrated in the **TYPE** parameter.
- Configure the lower and upper limits of indication for the maximum span of the selected input type.
- Go to the Calibration Level.
- Enter the access password.
- Enable calibration by setting YES in **CAL Ib** parameter.
- Using an electrical signals simulator, apply a signal a little higher than the **low** indication limit for the selected input.
- Access the parameter "**InLc**". With the keys **▲** and **▼** adjust the display reading such as to match the applied signal. Then press the **P** key.
- Apply a signal that corresponds to a value a little lower than the **upper** limit of indication.

- Access the parameter "**InLc**". With the keys **▲** and **▼** adjust the display reading such as to match the applied signal.
- Return to the Operation Level.
- Check the resulting accuracy. If not good enough, repeat the procedure.

Note: When checking the controller calibration with a Pt100 simulator, pay attention to the simulator minimum excitation current requirement, which may not be compatible with the 0.170 mA excitation current provided by the controller.

PART NUMBER FORMATION

N1040 -	A -	B
----------------	------------	----------

A: Outputs Features

- PR:** OUT1= Pulse / OUT2= Relay
- PRR:** OUT1= Pulse / OUT2=OUT3= Relay
- PRRR:** OUT1= Pulse / OUT2=OUT3= OUT4= Relay

B: Power Supply electric

- (Blank):**Model standard
..... 100~240 Vac / 48~240 Vdc; 50~60 Hz
- 24V:** Modelo 24V
..... 12~24 Vdc / 24 Vac

SPECIFICATIONS

- DIMENSIONS:** 48 x 48 x 80 mm
Cut-out in the panel: 45.5 x 45.5 mm (+0.5 -0.0 mm)
Approximate Weight: 75 g

POWER SUPPLY:

- Model standard: 100 to 240 Vac ($\pm 10\%$), 50/60 Hz
..... 48 to 240 Vdc ($\pm 10\%$)
- Model 24 V: 12 to 24 Vdc / 24 Vac (-10% / $+20\%$)
- Maximum consumption: 6 VA

ENVIRONMENTAL CONDITIONS:

- Operation Temperature: 0 to 50 °C
- Relative Humidity: 80 % @ 30 °C
..... For temperatures above 30 °C, reduce 3 % for each °C
- Internal use; Category of installation II, Degree of pollution 2; altitude < 2000 meters

INPUT Thermocouples **J; K; T** and **Pt100** (according of **Table 01**)

- Internal Resolution: 32767 levels (15 bits)
- Resolution of Display: 12000 levels (from -1999 up to 9999)
- Rate of Input Reading: up 10 per second (*)
- Precision: Thermocouples **J, K, T:** 0.25 % of the *span* ± 1 °C
..... Pt100: 0.2 % of the *span*
- Input Impedance: Pt100 and thermocouples: > 10 M Ω
- Measurement of Pt100: 3-wire type, ($\alpha=0.00385$)
With compensation for cable length, excitation current of 0.170 mA.

(*) Value adopted when the Digital Filter parameter is set to 0 (zero) value. For Digital Filter values other than 0, the Input Reading Rate value is 5 samples per second.

OUTPUTS

- OUT1: Voltage pulse, 5 V / 25 mA
- OUT2: Relay SPST; 1.5 A / 240 Vac / 30 Vdc
- OUT3: Relay SPST; 1.5 A / 240 Vac / 30 Vdc
- OUT4: Relay SPDT; 3 A / 240 Vac / 30 Vdc

FRONT PANEL: IP65, Polycarbonate (PC) UL94 V-2

ENCLOSURE: IP30, ABS+PC UL94 V-0

ELECTROMAGNETIC COMPATIBILITY: EN 61326-1:1997 and EN 61326-1/A1:1998

EMISSION:..... CISPR11/EN55011

IMMUNITY:..... EN61000-4-2, EN61000-4-3, EN61000-4-4, EN61000-4-5, EN61000-4-6, EN61000-4-8 and EN61000-4-11

SAFETY:..... EN61010-1:1993 and EN61010-1/A2:1995

SPECIFIC CONNECTIONS FOR TYPE FORK TERMINALS;

PROGRAMMABLE CYCLE OF PWM: from 0.5 up 100 seconds;

STARTS UP OPERATION: after 3 seconds connected to the power supply.

CERTIFICATION:  and  us.

SAFETY INFORMATION

Any control system design should take into account that any part of the system has the potential to fail. This product is not a protection or safety device and its alarms are not intended to protect against product failures. Independent safety devices should be always provided if personnel or property are at risk.

Product performance and specifications may be affected by its environment and installation. It's user's responsibility to assure proper grounding, shielding, cable routing and electrical noise filtering, in accordance with local regulations, EMC standards and good installation practices.

SUPPORT AND MAINTENANCE

This product contains no serviceable parts inside. Contact our local distributor in case you need authorized service.

LIMITED WARRANTY AND LIMITATION OF LIABILITY

NOVUS warrants to the original purchaser that this product is free from defects in material and workmanship under normal use and service within one (1) year from the date of shipment from factory or from its official sales channel to the original purchaser.

NOVUS liability under this warranty shall not in any case exceed the cost of correcting defects in the product or of supplying replacement product as herein provided and upon the expiration of the warranty period all such liability shall terminate.