

SEM206 P

- CONFIGURATION USING USB PORT POWERED CONFIGURATOR
- CONFIGURABLE IN SECONDS
- HIGH STABILITY
- OVER RANGE LED INDICATION
- PROGRAMMABLE BURNOUT
- 10 YEAR WARRANTY



INTRODUCTION

The SEM206/P is a cost effective “smart” in head transmitter that accepts PT100 temperature sensors and converts sensor output over a configured range to a standard industrial (4 to 20) mA transmission signal.

PC configuration allows the user to select Range, units and Burnout direction, without requiring calibration equipment. Configuration is performed quickly using our new USB port driven configurator by simply connecting two clips to the SEM206/P loop terminals and following the software instructions. Calibration set up may be saved as a file on the PC for later use.

The SEM206/P in head transmitter incorporates the latest digital technology to ensure accurate drift free performance.

If required the desired range can be specified at the time of order, removing the need for user configuration.
If the range is not specified then the transmitter will be shipped with the default range of 0 to 100 °C .

PC CONFIGURATION

EQUIPMENT

COMPUTER	Running Windows XP or later with USB port
USB CONFIGURATOR SUITE	Comprising: USB Configurator, Leads and Pen Drive with S/W

METHOD

- Load PC with USB_LINK software.
- Connect USB Configurator to PC USB port using cable.
- Connect Tool clips to SEM206 Loop Terminals Red (+) Black (-)
- Run software, set configuration required and save to device.

SPECIFICATIONS @ 20 °C

INPUT

Sensor Type	PT100 100 R @ 0 °C 2 or 3 Wire
Sensor Range	(-200 to +850) °C (18 to 390) Ω
Sensor Connection	Screw terminal
Minimum span (*1)	25 °C
Linearisation	BS EN 60751(IEC 751) standard / JISC 1604
Measurement Accuracy (*2)	0.1 °C ± 0.05 % of Reading
Thermal Drift	25 ppm / °C
Excitation current	<200 uA
Lead Resistance effect	0.002 °C / Ohms
Maximum lead Resistance	20 Ohms per leg

OUTPUT

Output Type	2 wire 4 to 20 mA current loop
Output range	(4.0 to 20.0) mA
Output Connection	Screw Terminal
Maximum output	21.5 mA (in high burnout condition)
Minimum output	3.8 mA (in low burnout condition)
Accuracy	(mA output / 2000) or 5 uA (Whichever is the greater)
Loop Voltage effect	0.2 uA / V
Thermal drift	1 uA / °C
Maximum output load	[(Vsupply-10)/20] K Ohms (Example: 700 Ohms @ 24V)

GENERAL SPECIFICATION

Update time	500 ms
Response Time	1 second
Start up time	4 seconds (I out < 4 mA during start up)
Warm-up time	1 minutes to full accuracy
Power Supply	(10 to 30) Volts dc

TEMPERATURE TRANSMITTERS

ENVIRONMENTAL

Ambient operating range (-40 to +85) °C
 Ambient storage temperature (-50 to +90) °C
 Ambient humidity range 10 to 90% RH non condensing

PHYSICAL

Dimensions 43 mm diameter; 21mm height
 Weight 31 g (encapsulated)

APPROVALS

EMC - BS EN 61326 :1998 - Electrical equipment for measurement control and laboratory use.

ANNEX A Immunity test requirements for equipment intended for use in industrial locations

ANNEX F Test configurations, operational conditions and performance criteria for transducers with integrated or remote signal conditioning.

IEC 61000-4-2 Electrostatic discharge
 IEC 61000-4-3 EM Field
 IEC 61000-4-4 Transient Burst (output)
 IEC 61000-4-5 Surge (output)

Note - Sensor input wires to be less than 3 metres to comply.

Note *1 Any span may be selected, full accuracy is only guaranteed for spans greater than the minimum recommended

Note *2 Basic measurement accuracy includes the effects of calibration, linearisation and repeatability

MECHANICAL

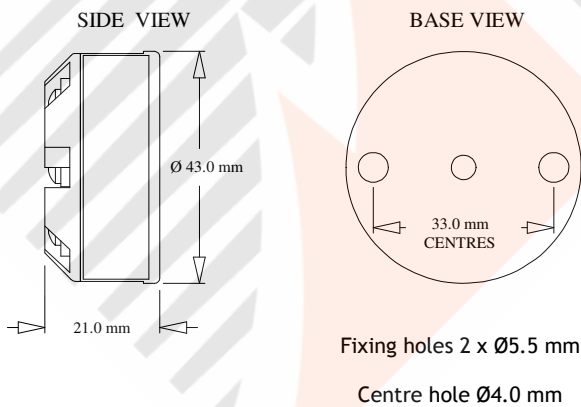

WIRING CONNECTIONS

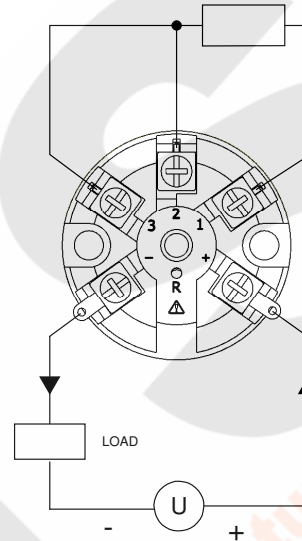

ORDER CODE: SEM 206P

ACCESSORIES: USB CONFIGURATOR SUITE USB-KIT